



HUNTS CAPACITOR ANALYSER

AND

RESISTANCE BRIDGE

TYPE CRB. SUPPLY VOLTS 210v. 250v. A.C. 50 CYCLES.

INTRODUCTION

In response to many requests by our trade friends for a bridge similar to our pre-war model, Type CLR 3221, we have now designed and produced a new Capacitor Analyser and Resistance Bridge, including the salient features of our pre-war model, but having many technical and constructional improvements which will be appreciated.

The bridge covers in 3 ranges capacitances of the order of 0.00001 to 50 mfd. Indications of Power Factor are obtainable on all ranges with a direct calibration on range C2 for use in the testing of Electrolytic Capacitors. Resistances of 50 ohms to 5 megohms are measured in two ranges. Provision is made for continuity test, electrolytic leakage and insulation indications, with many other miscellaneous applications, which in addition to the routine tests that may be performed make this instrument extremely useful to any Electrical Laboratory or Service Engineer. It is proposed to go into the tests in greater detail in later paragraphs.

The instrument has been designed to function for long periods without detriment to component life, making it immediately available for use, eliminating the time lag of valve heating. This has been made possible by incorporating mica and paper dielectric capacitors and dry

BRITISH MADE

Trade **HUNTS** Mark

rectifiers. The Cathode Ray Indicator which proved so successful in the CLR type bridge, has been retained with an interesting innovation adopted to conserve its life. This is achieved by arranging that the anode and target voltages are switched off in the standby " S " position of the range control.

The capacity and resistance scales are so related that the impedance of the capacitance C at 50 cycles is given directly on the resistance Range " R " so facilitating the solving of impedance network problems.

The instrument is housed in a robust metal cabinet, finished in crystalline black incorporating a strong metal chromium plated carrying handle, having the useful feature of acting as a stand during operation, to place the analyser off the vertical thus affording comfortable reading and handling of indicators and controls. A roomy compartment at the back accommodates the mains lead, plug adapter and test leads. The dial is clearly marked in black engraved lettering on a silver plated matt surface, fitted inside the instrument, and viewed through a perspex visor, thus affording perfect legibility with full protection against dust and damage. To complete a pleasing instrument finish all essential operational data is given on the top panel, in permanent embossed lettering on a black background.

This instrument combines a high degree of accuracy with a neat robust construction based on well tried technical principles.

BRITISH MADE

Trade **HUNTS** Mark.

SCHEDULE OF PARTS

The complete instrument comprises the following :

- One Instrument Type CRB.
- One Y63 Valve.
- One Neon Lamp 230v. 0.5 watt SBC.
- One pair Test Leads, Red and Black.
- One Mains Lead with 5 amp plug and Lamp Holder Adapter.
- One Instructional Manual with circuit diagram.

DIMENSIONS : $6\frac{1}{4}$ in. \times $9\frac{1}{8}$ in. \times 5 in.

WEIGHT : 10 lb.

INSTRUCTIONS

General

The analyser will be ready for use 30 seconds after application of mains supply. It is only necessary then to select the required range by means of the switch provided. *Note* : After making the requisite test, return range switch to " S ". This will automatically discharge the capacitor and makes the analyser immediately ready for subsequent tests, without affecting the component life. The Analyser can be run for long periods in this position.

The capacitance and resistance Ranges are bridge measurements and remain independent of mains variations, but the leakage depends on stability of supply volts and therefore should only be treated as an approximate indication.

Capacity and Power Factor Measurements of Paper, Mica, Electrolytic and Air Capacitors

<i>Range</i>	<i>Capacity</i>	<i>Power Factor Control</i>	<i>To Obtain Capacity</i>
C	0.001-0.5mfd.	0	Read Directly
C1	0.00001-0.005mfd.	0	Divide C by 100
C2	1-50mfd.	Adjust to suit Capacitor under test then read directly	Multiply C by 100

Connect the capacitor to the test terminals and then choose the appropriate range. Rotate control knob slowly until the shadow appears at a maximum on the cathode ray indicator. This is the balance position and the capacitance of the capacitor under test corresponds to that on the dial, either directly or multiplied or divided by the constant depending upon the selected range.

For Electrolytic capacitors, the procedure as above applies, with the addition that the power factor control is required to be adjusted for maximum balance. The power factor at 50 cycles is then read directly on the scale.

Certain limits shown below have been set as a guide in judging satisfactory capacitors. These limits have been chosen on the basis of our experience, and in general capacitors which meet this specification will be found satisfactory in operation. On the other hand it is known that capacitors used in certain specific circuits, may be more or possibly less critical with respect to specification. These cases can be handled best by intelligent use of the test instrument after studying the circuit and test characteristics.

SUGGESTED TEST LIMITS

Capacity

While capacitors should be within -30% of the rating for filter and by-pass use, there is no fixed upper limit with the exception of special cases, to be considered later.

Open Circuited Capacitors

Any capacitor which can only balance at open, should be replaced.

Intermittent Capacitors

Intermittent capacitors will test as "open" or "short" owing to the application of low A.C. volts. Suspect a capacitor for intermittent connection which gives a flickering effect on the cathode ray indicator. (Replace capacitor.)

High Power Factor

Where a balance is unobtainable on any point of the dial, it is a symptom of high power factor, and the capacitor requires replacing.

Short Circuit

Any capacitor which will only balance at the "short" position on the dial should be replaced. This can be confirmed by a leakage test.

For most filter applications, quite wide capacity variations are permissible. In some circuits, however, the capacities must be held

closely for best results. Some radio receivers utilise tuned choke filter systems; in such cases capacitances should be held within plus or minus 10% of the specified value. Resonant circuits and band-pass filters generally require that the capacitor values be held closely, but the limits must be determined individually for each special case.

In testing a capacitor of low value under 0.001 mfd., the test leads should be reduced to a minimum, and it is suggested that where accuracy is required, the capacitor should be connected as closely as possible to the terminals on the top panel.

Capacitors for Use in Filter Circuits

In ordinary filter use, capacitors for which a complete balance may be obtained on any setting of the Power Factor Control will generally be satisfactory, especially in the case of high voltage wet electrolytic capacitors.

The capacity range of most commercial electrolytic capacitors falls within the range of capacities covered with the switch "S" in position "C." While for most filter applications high power factors are not of importance provided they are within the range of the Power Factor scale of this instrument, some applications do require a lower power factor. One such application which although used is not recommended, is met where electrolytic capacitors are used as filters in the power supply and as R.F. by-pass capacitors at the same time, as in Fig. 1.

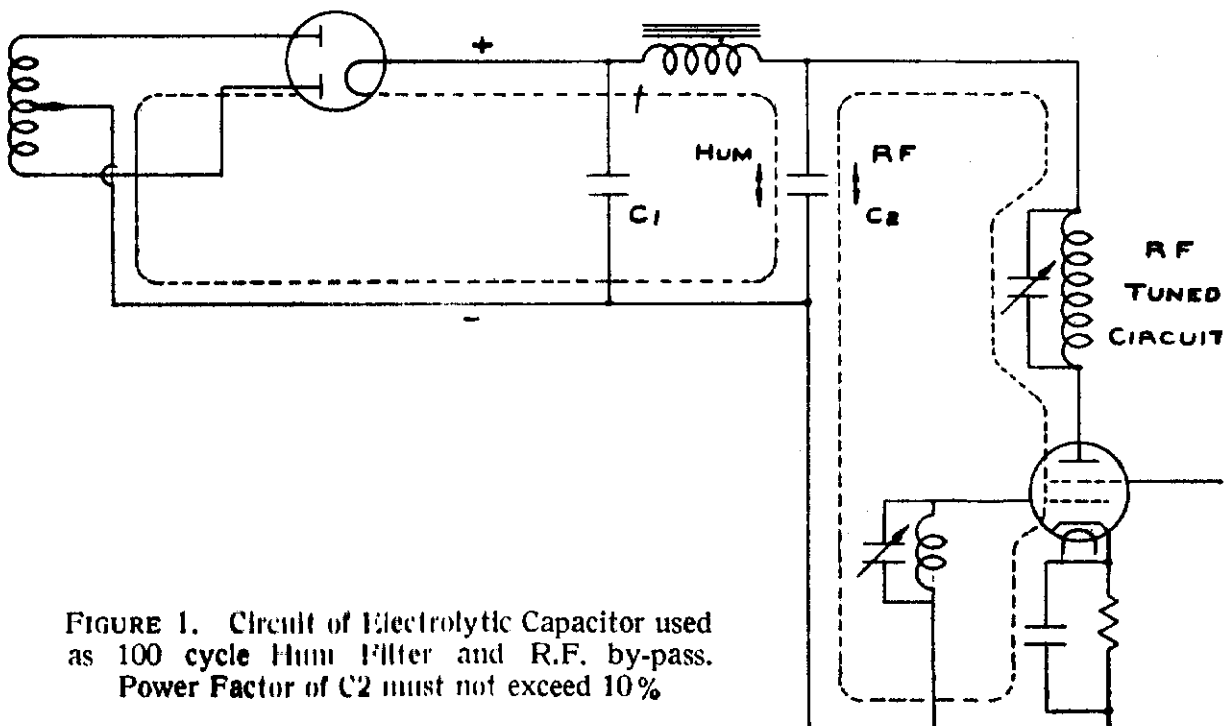

FIGURE 1. Circuit of Electrolytic Capacitor used as 100 cycle Hum Filter and R.F. by-pass. Power Factor of C2 must not exceed 10%

The power factor must be low enough so that the capacitor will not cause R.F. oscillation instability, interaction or loss of gain, when used in such circuits. The maximum power factor which can be tolerated in such circuits depends entirely on the particular receiver although in general if the power factor is below 10%, the capacitor will be satisfactory for this use.

Note.—If the power factor of C2 is preventing adequate by-passing a cure can be effected by connecting a paper or mica capacitor in parallel with it, thus allowing C2 to function as a 100 cycle hum filter and the mica or paper capacitor as a R.F. by-pass.

For applications other than R.F. by-passing, the power factors of electrolytic capacitors may run rather high and still give satisfactory service. Some types of capacitors, such as high voltage wet electrolytics and etched foil capacitors may be expected to have higher power factors than other types, without being in any respect inferior in operating qualities. For this reason, care must be exercised in drawing conclusions on the basis of power factor measurements.

The filtering efficiency of a capacitor is inversely proportional to its impedance. The latter is greater than that calculated from the measured capacitance C_m by an amount depending on the power factor and corresponds to a perfect capacitance C_p of rather lower value. For the filtering of the 50c/s ripple from a half-wave rectifier the equivalent perfect capacitance C_p is related to the measured capacitance C_m and the power factor PF by the formula—

$$C_p = C_m \sqrt{1 - (PF)^2}$$

provided that the power factor is less than 40% the following approximate formula applies :

$$C_p = C_m (1 - \frac{1}{2}(PF)^2)$$

and C_p will not differ from C_m by more than 8%

For the 100c/s applications, e.g., the filtering of a full-wave rectifier supply, the equivalent perfect capacitance will be rather lower than C_p as calculated above, owing to the fact that the power factor at 100c/s is rather higher than that measured at 50c/s, but in general will differ from C_p by less than 5%.

RESISTANCE TEST FOR ALL TYPES OF RESISTORS

<i>Range</i>	<i>Ohms</i>	<i>Read Scale</i>
R	5 Kilo Ohms to 5 Megohms	Directly
R1	50 Ohms to 50 Kilo Ohms	Divide R by 100

BRITISH MADE

Trade **HUNTS** Mark

Mode of operation is identical with that for capacitance measurements except in this case the resistance value is read on the " R " Scale.

As these are bridge measurements under A.C. conditions, it is not possible to measure the resistance of inductive components such as high inductance chokes and transformer windings, but indications of these can be made on the leakage section of the instrument.

STANDBY POSITION " S "

This position enables the analyser to be in a state of immediate readiness without having to wait for the valve cathode to heat. It can be run for long periods in this position without detriment to component life. The neon remains alight in this position and acts as a useful guide to ascertain whether the supply volts are to hand at the plug points.

CONTINUITY TEST ON L

Continuity tests are performed with the control switch in the L position. The neon will be observed to light on connecting the red and black leads together. This provides a convenient means of checking from point to point in a radio receiver.

LEAKAGE TEST ON ELECTROLYTIC CAPACITORS ON L1

Observation of the leakage conditions at 175v. of wet, ^{L1}dry, and etched foil electrolytic capacitors are made on the ~~L2~~ position of the instrument. On this test any capacitor which permanently lights the neon can be considered a reject. However, high voltage capacitors, i.e., 300—700v., suspected of high leak are better tested in the actual circuit, with a current meter. This method is recommended as a 500v. rated capacitor may only have 300v. applied at circuit conditions, but will immediately indicate as leaky if tested at the rated voltage, but will be quite in order after prolonged ageing. It is necessary to observe polarity when checking Electrolytic capacitors. *Caution.*—In checking capacitors under circuit operation for leak, keep meter shorted out during switching on, owing to the high surge currents encountered.

BRITISH MADE

Trade **HUNTS** Mark

Certain electrolytic capacitors end their useful life by loss of capacitance or developing a high resistance contact at the anode tab; these will not show up on leakage test, but will be evident on P.F. and capacitance checks.

By returning the range switch to the "S" or Standby position the capacitor will automatically discharge.

INSULATION ON RANGE L2

On Range L₂, 1 flash/sec. in the neon lamp is equivalent to a resistance of 100 megohms, the interval between flashes increasing and decreasing in direct proportion to the resistance.

This holds good for resistive elements and low capacities such as grid coupling capacitors, but the rate of flash is affected by high capacities in such a way that 100 megohm/mfd. is equivalent to 1 flash/sec.

The leakage of capacitors which will give one flash/sec. or less on the neon lamp will be found satisfactory for most applications with exception of grid coupling capacitors, shown as C in Fig. 2.

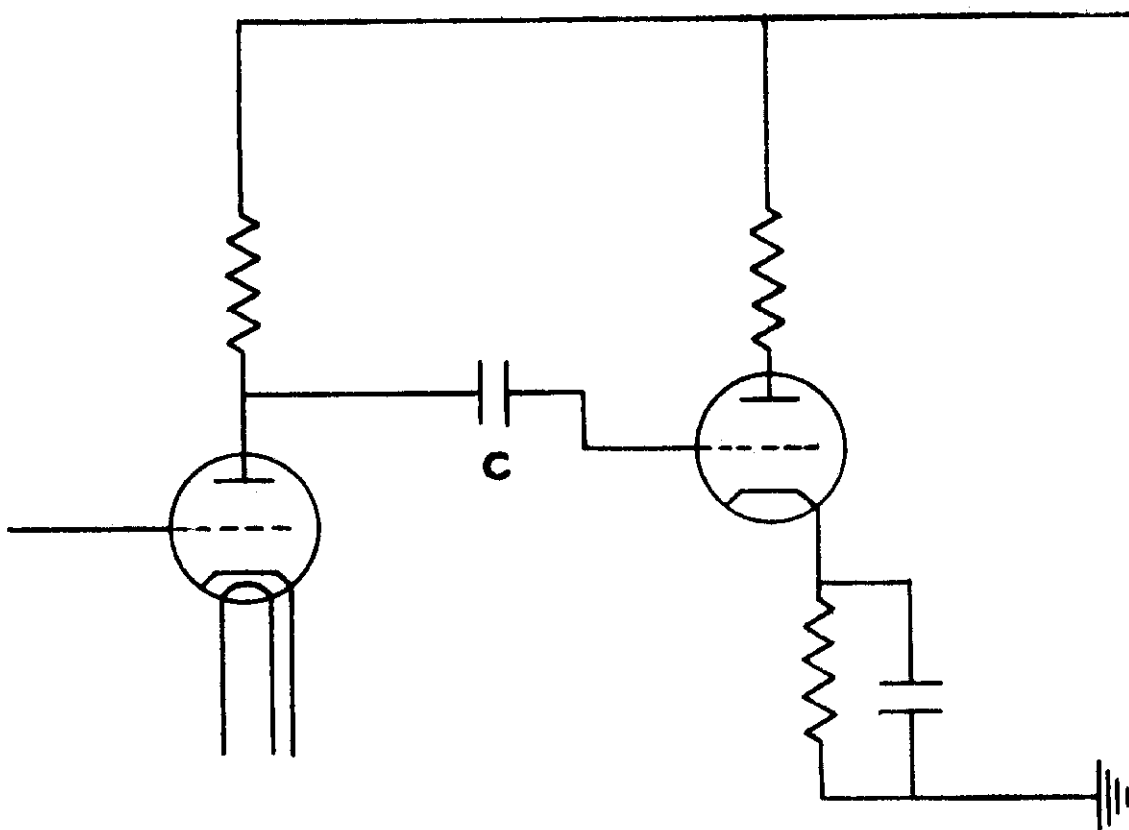

FIGURE 2. Grid Coupling Capacitor. Capacitors flashing more than once in 4 secs. should be rejected for this purpose

A leaky capacitor in this position will result in loss of bias voltage on V2 and any capacitor which flashes more frequently than once every 4 seconds should be considered a reject.

MISCELLANEOUS APPLICATIONS

In addition to the routine tests previously described, this test instrument may be used for other applications in both the laboratory and workshop. Some of which are given below.

The insulation resistance between coil windings, wires in cables, terminal strips, etc., can all be measured by observing the number of seconds per flash of the neon lamp and multiplying by 100 megohms.

$N = \text{No. of seconds/flash.}$

$R = \text{Resistance in megohms.}$

$R = 100 N.$

To check the insulation resistance of terminal strips one of the test lead clips should be connected to any of the terminals on the strip, the other test clip should be touched to the fibre or other insulating material of the terminal strip about 1/8 in. to 1/4 in. from the terminal lug. The resulting flashes of the neon "Leakage" lamp may be interpreted as described above to determine the resistance.

MEASUREMENT OF LEAKAGE BETWEEN SECTIONS IN MULTIPLE UNIT ELECTROLYTIC CAPACITORS

One difficulty which crops up quite often in practice is leakage between sections of multiple unit, dry electrolytic capacitors. This condition is very difficult to detect with ordinary test instruments but can be checked very easily by means of this test instrument.

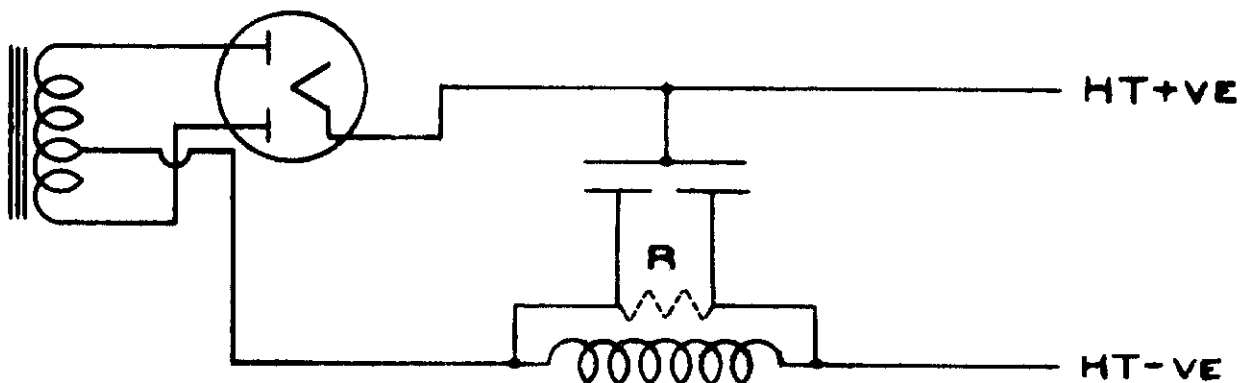

FIGURE 3. Negative Smoothing Utilising Common Positive Electrolytic Capacitors. R indicates leakage between Sections

The circuit shown in Figure 3 is typical of circuits using common positive electrolytic condensers. Leakage between negatives in this circuit shunts the choke in the negative lead and reduces its effectiveness, thereby increasing the hum level.

This condition may be detected in such units by connecting one of the sections, preferably the one of lowest capacity, to the test terminals of the instrument with the switch set to L.I. Measure the leakage in the regular manner and with the first section still connected to the test instrument, short together the negative lead of the second section to the common positive connection, as shown in figure. If there is appreciable leakage between sections, a very noticeable spark will occur every time the leads are shorted together. This test should be repeated several times, allowing about 5 seconds each time before the leads are shorted. If a slight spark is noticed the first time or after the leads are kept apart for considerably longer periods than five seconds, the leakage between sections may be neglected for all practical purposes.

CARE OF ANALYSER

Hunts Capacitance and Resistance Bridge brings to the Laboratory and Radio Service Engineers' Workshop the accuracy of the Wien Bridge method of measurement in its simplest form. It is a precision measuring instrument and should be treated as such.

Valve and Neon Lamps are available through Hunts distributors or from the factory.

VALVE REPLACEMENT

Should it be necessary to replace the valve, remove the 8 screws which hold the instrument into its case, also the shroud from valve. Ease valve from holder and remove from inside of chassis.

GUARANTEE

This instrument is guaranteed to perform as described and to be free from defects in materials and workmanship.

Any failure due to faulty materials or workmanship will be corrected without charge if the instrument is returned prepaid to Hunts factory within 90 days from date of purchase.

Should it be necessary to return the Instrument. It would be appreciated if full details of the fault are given.

A 05
 B 07
 C 07
 D 151000
 E 1592 01 170
 F 15000

BRITISH MADE
 Trade **HUNTS** Mark

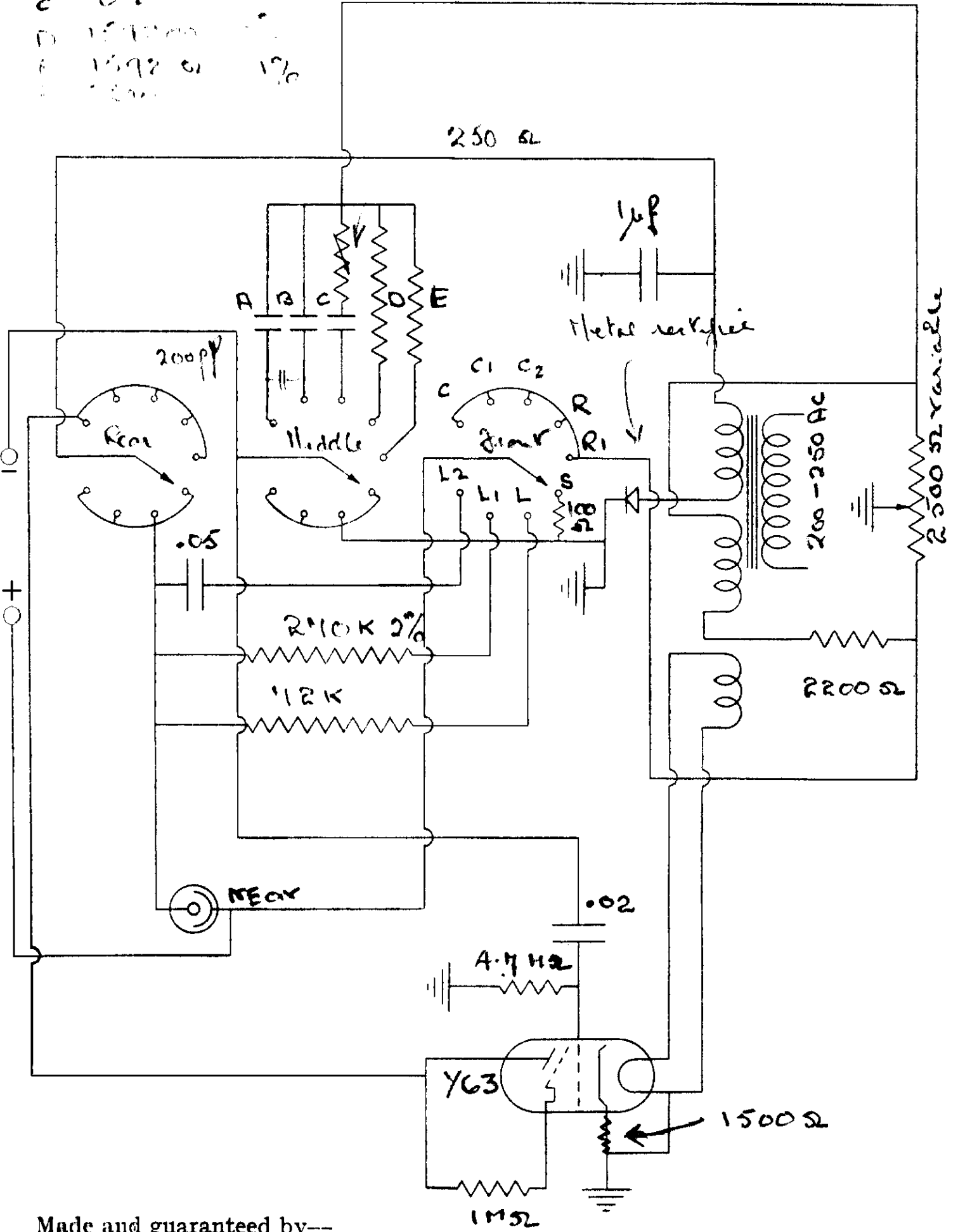

Made and guaranteed by—
 A. H. HUNT, LIMITED
 BENDON VALLEY, GARRATT LANE, WANDSWORTH, LONDON, S.W.18